

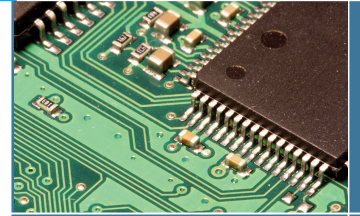

3DPIXA Stereo Line Scan Camera

PRECISION IN HIGH-RESOLUTION 3D AND COLOR

Chromasens 3DPIXA stereo line scan camera is a unique combination of line scan technology with fast stereo algorithms running on GPU. The 3DPIXA camera enables new 3D inspection and measuring applications requiring high resolutions.



UNIQUE FEATURES OF THE 3DPIXA TECHNOLOGY

- High speed inline 3D measurement
- Large field of view @ high resolution
- Height resolution up to 1 micron
- 2D resolution up to 5 micron
- 3D data and full color image in one scan
- Line scan frequencies up to 30 kHz @ full resolution
- Flexible use of all types of line illuminations
- Easy to use application programming interface (API)
- Integrated in standard machine vision libraries

APPLICATIONS OF 3DPIXA TECHNOLOGY

APPLICATIONS

- Height measurement
- Identifying micron defects
- Verification of height and 2D Position
- Combined 3D and color inspection
- 3D web inspection

Wirebond inspection

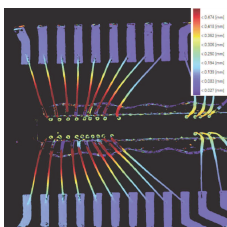

PCB inspection

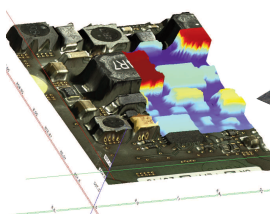

Food quality assessment



Metal surface inspection

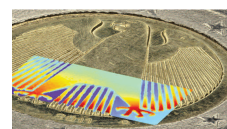

3DPIXA Stereo Line Scan Camera

PRECISION IN HIGH-RESOLUTION 3D AND COLOR

CAMERA SPECIFICATIONS

Camera	Stereo camera with lenses (factory calibrated)
Sensor	Tri-linear CCD line-sensor (RGB)
Active pixel size	10 μm x 10 μm
Interfaces	Camera Link Base/Medium/Full External I/O Serial (RS-232) Power supply (Hirose)
Power supply	Compact: 24 V DC +/- 10% 16 W Dual: 24 V DC +/- 10% 32/38 W
Trigger mode	Free run / external trigger
Operating temperature	0°C to 60°C, 32°F to 140°F (housing temperature)
Software	<ul style="list-style-type: none"> Chromasens 3D-API for real time 3D data calculation on NVIDIA GPU board (Windows x64) Chromasens 3D Viewer
Software output	Rectified color image (3x8 Bit) Height map (16 Bit) 3D point cloud
Supported software libraries	LabVIEW (National Instruments) HALCON (MVTec) MIL (Matrox) Coake (SAC)
Additional accessories	Chromasens Corona II illumination
Certifications	CE, FCC compliant, RoHS

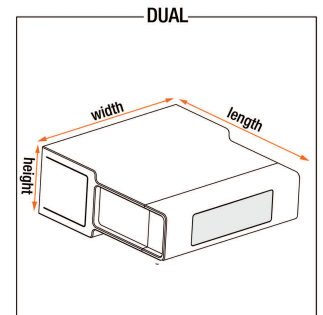
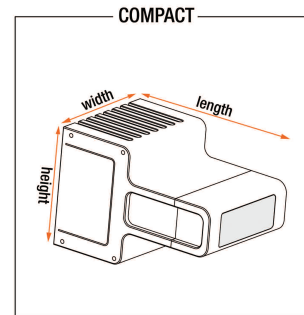
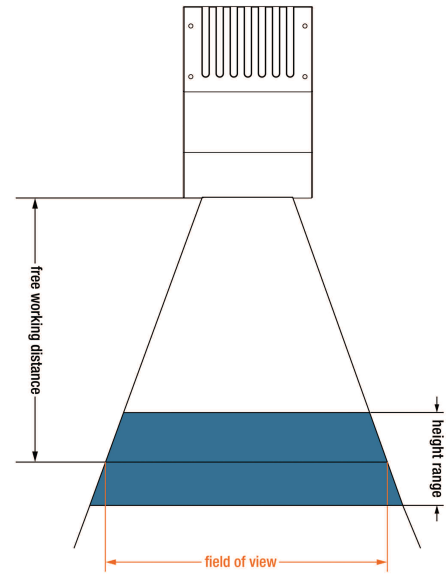

3DPIXA CONFIGURATIONS

3DPIXA MODEL NUMBERS	COMPACT		DUAL			
	CP000470-C01-015-0040	CP000470-C01-030-0105	CP000470-D01-005-0035	CP000520-D01-015-0105	CP000470-D01-030-0210	CP000470-D01-070-0500
Optical resolution ($\mu\text{m}/\text{px}$)	15	30	5	15	30	70
Field of view (mm)	40	105	35	105	210	500
Number of pixel	2666	3500	7000	7000	7000	7142
Height resolution (μm)*	3	10	1	3	5	14
Height range (mm) **	2.6	8.2	0.7	3.5	11.2	52.3
Free working distance (mm)	99.6	173.6	71.9	229	383.3	796.9
Maximum speed (mm/s)	310	630	100	440	630	1480
Camera Link configurations	Base/Medium	Base/Medium	Base/Medium	Base/Medium/Full	Base/Medium	Base/Medium
Line frequency (kHz)	21.2	21.2	21.2	29.7	21.2	21.2
Dimensions LxWxH (mm)	167.65 x 102 x 100	151.04 x 102 x 100	324 x 258 x 97	274 x 212.4 x 98.5	244 x 242 x 98.5	222 x 352 x 98.5

* Height range and height resolution depend on object surface

** For well structured surfaces the height range can exceed the specified values